

A Nonuniformly Spaced Microwave Photonic Filter Using a Spatially Discrete Chirped FBG

Chao Wang, *Member, IEEE*, and Jianping Yao, *Fellow, IEEE*

Abstract—We report an experimental demonstration of a nonuniformly spaced photonic microwave delay-line filter implemented using an incoherent broadband optical source and a spatially discrete chirped fiber Bragg grating (SD-CFBG). The SD-CFBG performs simultaneously three functions: 1) to slice the spectrum of the broadband optical source for generating the filter taps; 2) to provide nonuniform time delays; and 3) to control the weights of the filter taps. Since negative or complex coefficients are equivalently generated based on the nonuniform sampling, a filter with an arbitrary spectra response is achieved. To verify the effectiveness of the proposed method, a flat-top bandpass microwave filter with seven all-positive nonuniformly spaced taps at 12 GHz is experimentally demonstrated. The proposed method offers a cost-effective and easy-to-implement solution for photonic microwave filters having arbitrary frequency responses.

Index Terms—Dispersion, fiber Bragg grating (FBG), finite impulse response, microwave photonics.

I. INTRODUCTION

MICROWAVE photonics, an area that studies the interaction between microwave and optical wave for the generation, processing, control and distribution of microwave signals by means of photonics, has been a topic of interest in the past few decades, with numerous applications in both scientific and engineering fields [1]–[3]. Among the different topics, the implementation of microwave photonic filters in the optical domain has been considered an important solution for the processing of wideband and high frequency microwave signals, and numerous techniques have been proposed [4]–[6]. To avoid optical interferences which are extremely sensitive to environmental changes, microwave photonic delay-line filters are usually designed to operate in the incoherent regime. One limitation of an incoherent microwave photonic delay-line filter is the all positive nature of the tap coefficients. Based on signal processing theory, an all-positive delay-line filter can only operate as a low-pass filter with a linear phase response, which will fall short in practical applications. Therefore, a microwave photonic filter with negative coefficients having a

Manuscript received February 25, 2013; revised May 2, 2013; accepted August 19, 2013. Date of publication August 21, 2013; date of current version September 11, 2013. This work was supported by the Natural Sciences and Engineering Research Council of Canada.

C. Wang was with the Microwave Photonics Research Laboratory, School of Electrical Engineering and Computer Science, University of Ottawa, Ottawa, ON K1N 6N5, Canada. He is now with the School of Engineering and Digital Arts, University of Kent, Canterbury CT2 7NT, U.K. (e-mail: c.wang@kent.ac.uk).

J. Yao is with the Microwave Photonics Research Laboratory, School of Electrical Engineering and Computer Science, University of Ottawa, Ottawa, ON K1N 6N5, Canada (e-mail: jpyao@eecs.uOttawa.ca).

Color versions of one or more of the figures in this letter are available online at <http://ieeexplore.ieee.org>.

Digital Object Identifier 10.1109/LPT.2013.2279235

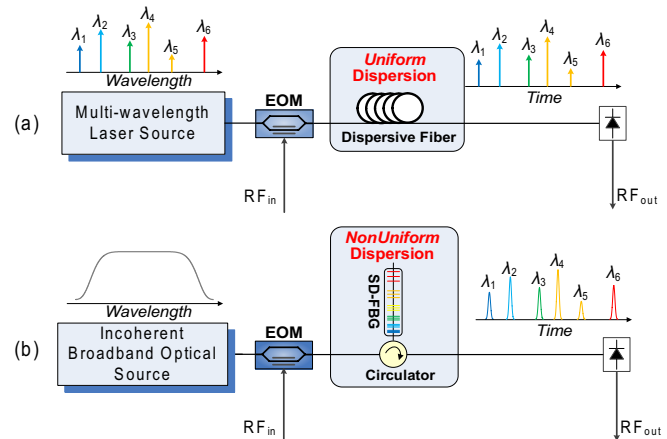

Fig. 1. A nonuniformly spaced photonic microwave delay-line filter implemented using (a) a multiwavelength laser source with nonuniformly spaced wavelengths and a uniform dispersive device (dispersive fiber), or (b) an incoherent broadband light source and a nonuniform dispersive device (SD-CFBG). EOM: electrooptic modulator, PD: photodetector, SD-CFBG: spatially-discrete chirped fiber Bragg grating.

bandpass response is desired for many applications. Extensive efforts have been devoted to the design and implementation of photonic microwave bandpass filters with negative tap coefficients. For example, a negative coefficient can be realized based on amplitude inversion via cross-gain modulation in a semiconductor optical amplifier (SOA) [7]. The use of the carrier depletion effect in a DFB laser diode can also generate a negative coefficient [8]. Negative coefficients can also be realized by biasing a pair of Mach–Zehnder modulators (MZMs) at the opposite slopes of the transfer functions [9]. The use of phase-modulation to intensity-modulation conversion can also generate a bandpass response [10]. Photonic microwave delay-line filters with complex coefficients have also been demonstrated to achieve arbitrary frequency responses [11]–[13]. However, those filters usually have complicated structures, which are hard to implement.

Recently, a new concept to implement a microwave photonic delay-line filter with negative or complex coefficients to generate an arbitrary spectra response based on nonuniform sampling [14] was proposed and demonstrated [15]. Negative or complex coefficients are generated by introducing nonuniformly-spaced time delays among the filter taps. Since the actual tap coefficients are all positive, the filter is easy to implement. The nonuniformly spaced time delays are usually achieved by using a multi-wavelength laser source with nonuniformly spaced wavelengths and a linear dispersive

element. Fig. 1(a) shows the structure of such a filter. Since the time delays are uniquely determined by the wavelength spacing, a laser array with high wavelength accuracy is critical, which may make the system bulky and costly, especially for a filter with a large number of taps.

Recently, an approach to implementing a nonuniformly spaced multi-tap photonic microwave filter using a broadband light source and a spatially discrete chirped fiber Bragg grating (SD-CFBG) was proposed and theoretically studied [16]. The work here reports the first experimental demonstration of the technique. The demonstrated filter features a significantly reduced size and cost. The key component in the filter is the SD-CFBG, which performs three functions, to slice the spectrum of the broadband optical source, to provide nonuniform time delays, and to tailor the weights of the filter taps. A seven-tap bandpass microwave photonic filter with all-positive and nonuniformly spaced taps having a flat top centered at 12 GHz is experimentally demonstrated. The filter can find applications in microwave signal processing where a low-cost filter with an arbitrary spectral response is needed.

II. PRINCIPLE

The impulse response of a uniformly spaced delay-line filter can be expressed as

$$h(t) = \sum_{k=0}^{N-1} a_k \delta(t - kT) \quad (1)$$

where N is the tap number, a_k is the tap coefficient of the k th tap, which could be complex-valued, and T is the uniform time delay difference. Eq. (1) can be further written as

$$h(t) = \sum_{k=0}^{N-1} a(kT) \delta(t - kT) = \sum_{k=0}^{N-1} a(t) \delta(t - kT) \quad (2)$$

where $a(t)$ is the coefficient profile. Based on (2) the frequency response is given by calculating its Fourier transform,

$$H(\omega) = \sum_m \frac{1}{2\pi} A(\omega) * \Omega \delta(\omega - m\Omega) = \sum_m \frac{1}{T} A(\omega - m\Omega) \quad (3)$$

where $\Omega = 2\pi/T$ is the free spectral range (FSR), $A(\omega)$ is the Fourier transform of $a(t)$, and $*$ denotes the convolution operation. As can be seen the frequency response is periodic with a period equal to the FSR, and the frequency response at the m -th channel is given by $\frac{1}{T} A(\omega - m\Omega)$.

If the time delays between the filter taps are nonuniformly spaced, then a time delay offset between two adjacent taps will be resulted which would contribute to an additional phase shift, and thus an equivalent complex coefficient is generated [15]. To design an nonuniformly spaced delay-line filter with its frequency response at the m -th channel that is identical to $\frac{1}{T} A(\omega - m\Omega)$, the time delay, τ_k , and tap coefficient, β_k , of the k -th nonuniformly spaced tap are given by [17],

$$\tau_k = kT - f(\tau_k) \quad (4a)$$

$$\beta_k = \left| \frac{a(\tau_k)}{1 + f'(\tau_k)} \right| \quad (4b)$$

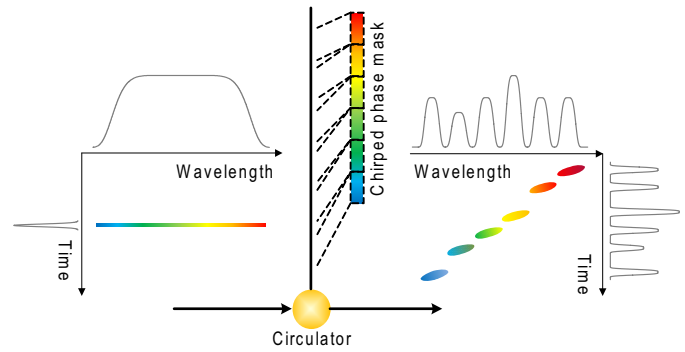

Fig. 2. An SD-CFBG that consists of multiple sub-gratings. The reflection spectrum and time delay response are also shown.

where $f(t) = \phi(t)/m\Omega$ is a nonuniform time delay shifting function, and $\phi(t)$ is the phase of $a(t)$. Based on (4), a delay-line filter with an arbitrary frequency response at the m -th channel can be realized with all-positive tap coefficients via nonuniform sampling.

Typically, nonuniformly-spaced time delays are implemented using a tunable laser array with nonuniformly spaced wavelengths [15]. The magnitude of each tap is controlled by tuning the optical power of the corresponding wavelength [15]. Therefore, the system is complicated and costly. In our proposed technique, a low-cost incoherent broadband light source, such as an amplified spontaneous emission (ASE) source, is used, and the time delays and the tap weights are controlled by a single SD-CFBG through spectrum slicing, as shown in Fig. 1(b). Spectrum-slicing has been a viable technique to provide a low-cost solution for realizing a large number of taps [18]–[20]. Note that the use of an ASE source would produce significant excess intensity noise, a dominant source of noise that limits the filter performance. A comprehensive analysis of the noise properties has been performed and noise mitigation strategies have been proposed [21]. We expect that the proposed technique is useful for applications where an easy and low-cost implementation of a sophisticated microwave photonic filter is required.

For a delay-line filter with a given spectral response, the SD-CFBG is designed to have a multichannel spectral response with the reflectivities corresponding to the tap weights and a discrete (jumped) group delay response corresponding to the nonuniform time delays. Since only a broadband light source and a single SD-CFBG are used, the implementation of the designed delay-line filter is greatly simplified.

An SD-CFBG is a special FBG that consists of multiple spatially separated sub-gratings [22]. An SD-CFBG can be fabricated from a linearly chirped FBG (LCFBG) by introducing spatial separations, as shown in Fig. 2. The reflectivity of each sub-grating, corresponding to the tap coefficient β_k , can also be precisely controlled by directly modulating the refractive index of the fiber grating [23]. The time delay of the k -th sub-grating is given by [22],

$$\tau_k = k \frac{\lambda_{\Delta}}{c} \times \frac{2n_{eff}}{c} + \sum_{k=1}^k d_k \times \frac{2n_{eff}}{c} \quad (5)$$

where λ_Δ is the constant wavelength spacing between adjacent sub-gratings, C is the chirp rate of the original LCFBG, n_{eff} is the effective refractive index of the fiber core, c is the light speed in vacuum, and d_k is the spatial spacing between the k -th and $(k+1)$ -th sub-gratings. The first term on the right-hand side represents a linear group delay which generates a constant time delay T , and the second term denotes the discrete delay jumps which contribute to the nonuniform time delays. According to (4a) and (5), we can determine the spatial spacing for a given wavelength spacing,

$$\sum_{i=1}^k (d_i - d_0) \times \frac{2n_{eff}}{c} = -f(\tau_k) \quad (6)$$

where $d_0 = \frac{1}{2} \left(\frac{T \times c}{n_{eff}} - \frac{\lambda_\Delta}{C} \right)$ is the constant spatial spacing between two adjacent sub-gratings. Note that the inherent dispersion of the SD-CFBG may cause power fading effect. For an SD-CFBG with a value of dispersion of χ , the power fading effect can be ignored if the condition $\frac{\chi \lambda^2 \omega^2}{c} < \frac{\pi^2}{2}$ is satisfied. In our design, the condition is well satisfied and the power fading effect is not considered.

III. DESIGN AND EXPERIMENT

A nonuniformly-spaced microwave delay-line filter using an SD-CFBG with a flat-top bandpass centered at 12 GHz is experimentally demonstrated. We start the design of the bandpass filter from its frequency response at the m -th channel $\frac{1}{T}A(\omega - m\Omega)$. In our design, the frequency response with a shape close to a rectangle is considered. The impulse response and the filter coefficients are obtained from the inverse Fourier transform of $\frac{1}{T}A(\omega - m\Omega)$. Here as a proof-of-principle demonstration, the filter is implemented with seven taps and the desired passband is at the first channel ($m = 1$). According to (4a) and (4b), the all-positive filter coefficients are calculated to be $[0.12, 0, 0.64, 1, 0.64, 0, 0.12]$ and the nonuniformly spaced time delays are $[0, 0.5T, 1.5T, 2.5T, 3.5T, 4.5T, 5T]$, where the constant time delay difference T is 83.3 ps, corresponding to the center frequency of the first channel at 12 GHz.

The frequency response of the designed nonuniformly spaced filter is calculated and shown in Fig. 3. As can be seen that the passband at the 1st channel has a flat top and the center frequency is 12 GHz, which is identical to the designed value. The 3-dB bandwidth is 5.1 GHz. As a comparison, the frequency response of a regular uniformly spaced filter with true negative coefficients of $[-0.12, 0, 0.64, 1, 0.64, 0, -0.12]$ is calculated and is also shown in Fig. 3. As expected, the frequency response of the nonuniformly spaced microwave photonic filter at the 1st channel matches well with that of the regular uniformly spaced filter.

The key device in the filter is the SD-CFBG, which is fabricated using a linearly chirped phase mask by axially shifting the fiber to introduce the required spatial spacing between two adjacent sub-gratings during the fabrication process [22]. The linearly chirped phase mask has a chirp rate of 2.4 nm/cm. The wavelength spacing between adjacent channels is selected to be 2 nm. Fig. 4 shows the magnitude response and the

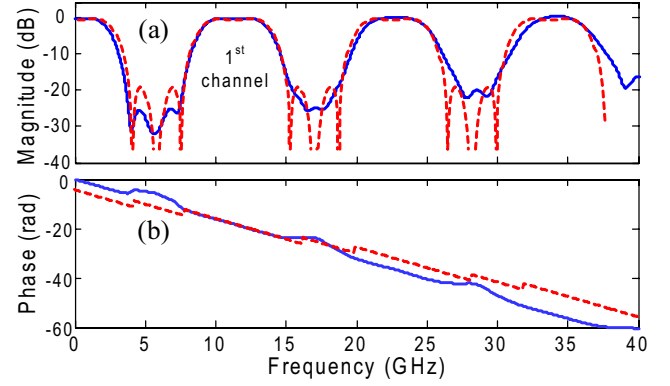

Fig. 3. The frequency responses of the designed nonuniformly spaced photonic microwave delay-line filter (solid line) and the regular uniformly spaced filter (dashed line). Both filters are designed to achieve the same flat-top bandpass filter response at the 1st channel. (a) Magnitude response, and (b) phase response.

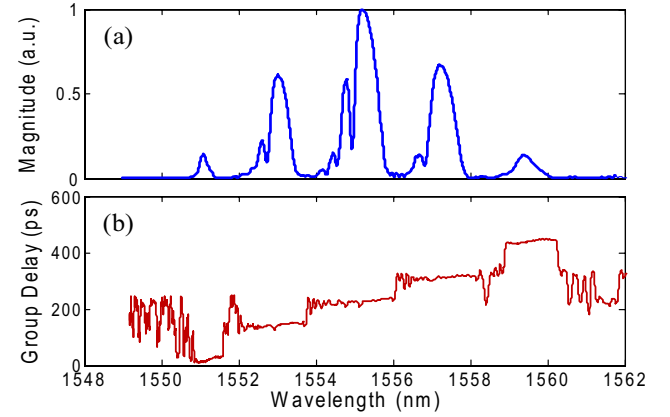

Fig. 4. (a) Normalized magnitude response and (b) group delay response of the fabricated SD-CFBG, measured by an optical vector analyzer.

group delay response of the fabricated SD-CFBG, measured by an optical vector analyzer (Luna Technologies). Since two of the seven filter coefficients are zero, the SD-CFBG has a reflection response having five channels with their reflectivities measured to be $[0.15, 0.61, 1, 0.66, 0.14]$. Equivalent negative coefficients are achieved by introducing half group delay jumps to the first and last optical wavelengths, as shown in Fig. 4(b).

The fabricated SD-CFBG is then incorporated into the filter shown in Fig. 1(b). An ASE light source from an erbium-doped fiber amplifier (EDFA) with a wide spectral range at the 1550 nm band is used as the incoherence light source. Its spectrum is flattened by using a configurable optical spectral shaper (Finisar WaveShaper 4000S). The broadband light source is then modulated by a microwave signal at the MZM and sent to the SD-CFBG. The SD-CFBG performs three functions, to slice the spectrum of the broadband optical source, to provide nonuniform time delays, and to tailor the weights of the filter taps. The optical signals at the output of the SD-FBG are then applied to the PD. The frequency response of the nonuniformly spaced microwave filter is then measured using a vector network analyzer (VNA, Agilent E8364A), with the results shown in Fig. 5. A flat-top bandpass filter

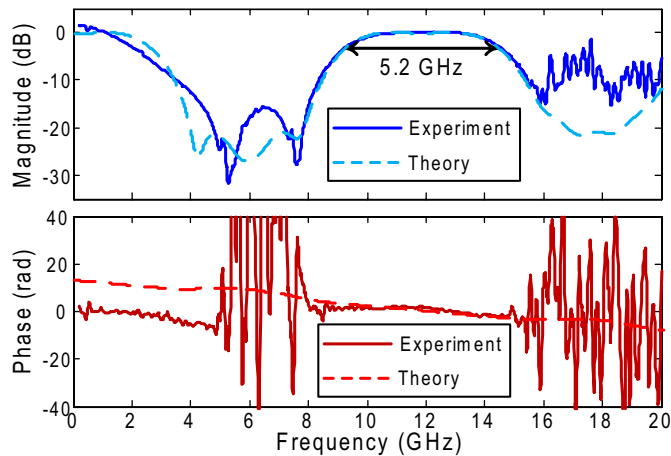

Fig. 5. The measured (solid line) and theoretical (dashed line) spectral response of the nonuniformly spaced photonic microwave delay-line filter based on an SD-CFBG. (a) Magnitude response, and (b) phase response.

with a 3-dB bandwidth of 5.2 GHz is achieved at the first-order channel centered at 12 GHz. The spectral response of an ideal filter is calculated which is shown in Fig. 5 for comparison. As can be seen within the passband, the spectral response (both magnitude and phase) of the experimentally demonstrated filter and that of the ideal filter agree well. Note that a low-pass response at the baseband is also observed, which can be eliminated by replacing the MZM with a phase modulator [15].

IV. DISCUSSION AND CONCLUSION

A new technique to significantly simplify the implementation of a photonic microwave delay-line filter with an arbitrary spectral response based on nonuniform sampling to generate equivalent complex coefficients using an SD-CFBG was proposed and investigated. The key component in the proposed filter was the SD-CFBG, which performed simultaneously three functions: to slice the broadband optical spectrum for generating the filter taps, to provide nonuniform time delays, and to control the tap coefficients. An SD-CFBG was designed and fabricated. A seven-tap nonuniformly spaced microwave photonic filter with a passband centered at 12 GHz having a flat top was demonstrated.

REFERENCES

- [1] J. Capmany and D. Novak, "Microwave photonics combines two worlds," *Nature Photon.*, vol. 1, no. 6, pp. 319–330, Jun. 2007.
- [2] A. J. Seeds and K. J. Williams, "Microwave photonics," *J. Lightw. Technol.*, vol. 24, no. 12, pp. 4628–4641, Dec. 2006.
- [3] J. P. Yao, "Microwave photonics," *J. Lightw. Technol.*, vol. 27, no. 3, pp. 314–335, Feb. 1, 2009.

- [4] J. Capmany, B. Ortega, and D. Pastor, "A tutorial on microwave photonic filters," *J. Lightw. Technol.*, vol. 24, no. 1, pp. 201–209, Jan. 2006.
- [5] R. A. Minasian, "Photonic signal processing of microwave signals," *IEEE Trans. Microw. Theory Tech.*, vol. 54, no. 2, pp. 832–846, Feb. 2006.
- [6] J. Capmany, B. Ortega, D. Pastor, and S. Sales, "Discrete-time optical processing of microwave signals," *J. Lightw. Technol.*, vol. 23, no. 2, pp. 702–723, Feb. 2005.
- [7] F. Coppinger, S. Yegnanarayanan, P. D. Trinh, and B. Jalali, "All-optical RF filter using amplitude inversion in a semiconductor optical amplifier," *IEEE Trans. Microw. Theory Tech.*, vol. 45, no. 8, pp. 1473–1477, Aug. 1997.
- [8] S. Li, K. S. Chiang, W. A. Gambling, Y. Liu, L. Zhang, and I. Bennion, "A novel tunable all-optical incoherent negative-tap fiber-optic transversal filter based on a DFB laser diode and fiber Bragg gratings," *IEEE Photon. Technol. Lett.*, vol. 12, no. 9, pp. 1207–1209, Sep. 2000.
- [9] J. Capmany, D. Pastor, A. Martinez, B. Ortega, and S. Sales, "Microwave photonics filters with negative coefficients based on phase inversion in an electro-optic modulator," *Opt. Lett.*, vol. 28, no. 16, pp. 1415–1417, Aug. 2003.
- [10] F. Zeng and J. P. Yao, "All-optical bandpass microwave filter based on an electro-optical phase modulator," *Opt. Express*, vol. 12, no. 16, pp. 3814–3819, Aug. 2004.
- [11] N. You and R. A. Minasian, "A novel tunable microwave optical notch filter," *IEEE Trans. Microw. Theory Tech.*, vol. 49, no. 10, pp. 2002–2005, Oct. 2001.
- [12] Y. Yan and J. P. Yao, "A tunable photonic microwave filter with a complex coefficient using an optical RF phase shifter," *IEEE Photon. Technol. Lett.*, vol. 19, no. 10, pp. 1472–1474, Oct. 1, 2007.
- [13] A. Loayssa, J. Capmany, M. Sagues, and J. Mora, "Demonstration of incoherent microwave photonic filters with all-optical complex coefficients," *IEEE Photon. Technol. Lett.*, vol. 18, no. 8, pp. 1744–1746, Aug. 15, 2006.
- [14] F. A. Marvasti, *Nonuniform Sampling: Theory and Practice*. New York, NY, USA: Plenum, 2001.
- [15] Y. Dai and J. P. Yao, "Nonuniformly-spaced photonic microwave delay-line filter," *Opt. Express*, vol. 16, no. 7, pp. 4713–4718, Mar. 2008.
- [16] C. Wang and J. P. Yao, "Nonuniformly spaced photonic microwave delay-line filter using a spatially discrete chirped fiber Bragg grating," in *Proc. IEEE Int. Topical Meeting Microw. Photon. Conf.*, Oct. 2011, pp. 437–440.
- [17] Y. Dai and J. P. Yao, "Nonuniformly spaced photonic microwave delay-line filters and applications," *IEEE Trans. Microw. Theory Tech.*, vol. 58, no. 11, pp. 3279–3289, Nov. 2010.
- [18] D. B. Hunter and R. A. Minasian, "Microwave optical filters using in-fiber Bragg grating arrays," *IEEE Microw. Guided Wave Lett.*, vol. 6, no. 2, pp. 103–105, Feb. 1996.
- [19] J. Mora, B. Ortega, J. Capmany, J. L. Cruz, M. V. Andres, D. Pastor, and S. Sales, "Automatic tunable and reconfigurable fiber-optic microwave filters based on a broadband optical source sliced by uniform fiber Bragg gratings," *Opt. Express*, vol. 10, no. 22, pp. 1291–1298, Nov. 2002.
- [20] X. K. Yi and R. A. Minasian, "New spectrum-sliced microwave photonic filter for high-frequency signal processing," *IEEE Photon. Technol. Lett.*, vol. 21, no. 4, pp. 230–232, Feb. 15, 2009.
- [21] X. K. Yi and R. A. Minasian, "Noise mitigation in spectrum sliced microwave photonic signal processors," *J. Lightw. Technol.*, vol. 24, no. 12, pp. 4959–4965, Dec. 2006.
- [22] C. Wang and J. P. Yao, "Large time-bandwidth product microwave arbitrary waveform generation using a spatially discrete chirped fiber Bragg grating," *J. Lightw. Technol.*, vol. 28, no. 11, pp. 1652–1660, Jun. 1, 2010.
- [23] C. Wang and J. P. Yao, "Simultaneous optical spectral shaping and wavelength-to-time mapping for photonic microwave arbitrary waveform generation," *IEEE Photon. Technol. Lett.*, vol. 21, no. 12, pp. 1493–1495, Jun. 15, 2009.